

A TRUE COPY
CERTIFICATION ON LAST PAGE
J.K. BARTON, CLERK

BY-LAWS
OF
SPINDRIFT CONDOMINIUM ASSOCIATION OF VERO BEACH, INC.

1. IDENTITY

These are the By-Laws of SPINDRIFT CONDOMINIUM ASSOCIATION OF VERO BEACH, INC., a corporation not for profit under the laws of the State of Florida, the Articles of Incorporation of which were filed in the office of the Secretary of State on June 30, 1981. Spindrift Condominium Association of Vero Beach, Inc., hereinafter called "Association", has been organized for the purpose of administering the operation and management of a Condominium to be established by The Spindrift Corporation of Vero Beach, a Florida corporation, hereinafter sometimes called "Developer", upon lands owned by it and as described in Article II of said Articles of Incorporation.

a. All present or future owners, tenants, future tenants or their employees or any other person who might use the Condominium, or any of the facilities thereof in any manner, are subject to the regulations as set forth in these By-Laws and in said Articles of Incorporation and the Declaration of Condominium.

b. The office of the Association shall initially be at 1025 Flamevine Lane, Vero Beach, Indian River County, Florida.

c. The fiscal year of the Association shall be the calendar year, January 1 through December 31.

d. The seal of the Association shall bear the name of the Association, the word "Florida", the words "Corporation Not For Profit", and the year of incorporation, an impression of which seal is as follows:

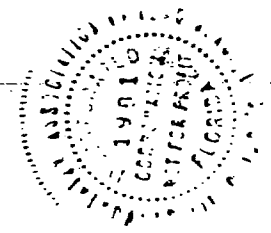

2. MEMBERSHIP, VOTING, QUORUM, PROXIES

a. The qualification of members, the manner of their admission to membership and termination of such membership, and voting by members shall be as set forth in Article IV of the Articles of Incorporation are incorporated herein by reference.

Exhibit "D"

ATRUE COPY
CERTIFICATION ON LAST PAGE
J.K. BASTON, CLERK

b. A quorum at members' meetings shall consist of persons entitled to cast a majority of the votes of the entire membership. The joinder of a member in the action of a meeting by signing and concurring in the minutes thereof shall constitute the presence of such person for the purpose of determining a quorum.

c. The vote of the owners of a Condominium Unit owned by more than one person or by a corporation or other entity shall be cast by the person named in a certificate signed by all of the owners of the Unit and filed with the Secretary of the Association, and such certificate shall be valid until revoked by subsequent certificate. If such a certificate is not on file, the vote of such owners shall not be considered in determining the requirement for a quorum, nor for any other purpose.

d. Votes may be cast in person or by proxy. Proxies shall be valid only for the particular meeting designated thereon and must be filed with the Secretary before the appointed time of the meeting.

e. Approval or disapproval of a Unit owner upon any matters, whether or not the subject of an Association meeting, shall be by the same person who would cast the vote of such owner if in an Association meeting.

f. Except where otherwise required under the provisions of the Articles of Incorporation of the Association, these By-Laws, the Declaration of Condominium, or where the same may otherwise be required by law, the affirmative vote of a majority of the members, represented at any duly called members' meeting at which a quorum is present, shall be binding upon the members.

3. ANNUAL AND SPECIAL MEETINGS OF MEMBERSHIP

a. The annual members' meeting shall be held at the office of the Association during the month of January of each year for the purpose of electing Directors and of transacting any other business authorized to be transacted by the members.

b. Special members' meetings shall be held whenever called by the President or Vice President, or by a majority of the Board of Directors, and must be called by such officers upon receipt of a written request from a majority of members of the Association.

c. Notice of all members' meetings, regular or special, shall be given by the President, Vice President or Secretary of the Association, or other officer of the Association in absence of said officers, to each member, unless waived in writing, such notice to be written or printed and to state the time and place and object for which the meeting is called. Such notice shall be given to each

member not less than ten (10) days nor more than sixty (60) days prior to the date set for such meeting, which notice shall be mailed or presented personally to each member within said time. If presented personally, receipt of such notice shall be signed by the member, indicating the date on which such notice was received by him. If mailed, such notice shall be deemed to be properly given when deposited in the United States mail addressed to the member at his post office address as it appears on the records of the Association, the postage thereon prepaid. Such mailing shall be evidenced by the affidavit of the person giving such notice. Any member may, by written waiver of notice signed by such member, waive such notice, and such waiver, when filed in the records of the Association, whether before or after the holding of the meeting, shall be deemed equivalent to the giving of such notice to such member. If any members' meeting cannot be organized because a quorum has not attended, or because the greater percentage of the membership required to constitute a quorum for particular purposes has not attended, wherever the latter percentage of attendance may be required as set forth in the Articles of Incorporation, these By-Laws or the Declaration of Condominium, the members who are present, either in person or by proxy, may adjourn the meeting from time to time until a quorum, or the required percentage of attendance if greater than a quorum, is present.

d. The order of business at annual members' meeting and, as far as practical, at any other members' meeting, shall be:

- (i) Election of Chairman of the meeting;
- (ii) Calling of the roll and certifying of proxies;
- (iii) Proof of notice of meeting or waiver of notice;
- (iv) Reading and disposal of any unapproved minutes;
- (v) Reports of officers;
- (vi) Reports of committees;
- (vii) Election of directors;
- (viii) Unfinished business;
- (ix) New business;
- (x) Adjournment.

4. BOARD OF DIRECTORS

a. The first Board of Directors of the Association, and succeeding Boards of Directors, shall consist of not less than three (3) nor more than nine (9) persons. At least a majority of the Board of Directors shall be members of the Association, or shall be authorized representatives, officers or employees of a corporate member of the Association; provided that members of the Board of Directors designated by The Spindrift Corporation of Vero Beach (hereinafter referred to as "Developer"), as hereinafter provided, need not be members of the Association. When Unit owners other than the Developer own fifteen percent (15%) or more of the Units that will be operated ultimately by the Association,

ATRUE COPY
CERTIFICATION ON LAST PAGE
J.K. BARTON, CLERK

the Unit owners other than the Developer shall be entitled to elect not less than one third (1/3) of the members of the Board of Directors of the Association. Unit owners other than the Developer shall be entitled to elect not less than a majority of the members of the Board of Directors of the Association three (3) years after sales by the Developer have been closed of fifty percent (50%) of the Units that will be operated ultimately by the Association, three (3) months after sales have been closed by the Developer of ninety percent (90%) of the Units that will be operated ultimately by the Association, or when all of the Units that will be operated ultimately by the Association have been completed, some of them have been sold, and none of the others are being offered for sale by the Developer in the ordinary course of business, whichever shall first occur. The Developer shall be entitled to elect not less than one member of the Board of Directors of the Association as long as the Developer holds for sale in the ordinary course of business any Units in the Condominium operated by the Association. Whenever Developer shall be entitled to designate and select any person or persons to serve on any Board of Directors of Association, the manner in which such person or persons shall be designated shall be as provided in the Articles of Incorporation or By-Laws of Association, and Developer, or Developer's successors or assigns, shall have the right to remove any person or persons selected by it to act and serve on said Board of Directors and to replace such person or persons with another person or persons to act and serve in the place of any Director or Directors so removed for the remainder of the unexpired term of any Director or Directors so removed. Any Director designated and selected by Developer need not be a resident in the Condominium or a member of Association.

b. Election of Directors shall be conducted in the following manner:

(i) Developer shall, at the beginning of the election of the Board of Directors, designate and select that number of the members of the Board of Directors which it shall be entitled to designate and select in accordance with the provisions of these By-Laws, and upon such designation and selection by Developer by written instrument presented to the meeting at which such election is held, said individuals so designated and selected by Developer shall be deemed and considered for all purposes Directors of the Association, and shall thereafter perform the offices and duties of such Directors until their successors shall have been selected or elected in accordance with the provisions of these By-Laws. Should Developer fail to designate and select members of the Board of Directors at any time while the said Developer is entitled to designate and select members of the Board of Directors as herein provided, those members of the Board of Directors previously designated and selected by Developer shall continue to serve as members of the Board of Directors as though designated and selected as herein provided.

(ii) All members of the Board of Directors whom Developer shall not be entitled to designate and select under the terms and provisions of these By-Laws shall be elected by a plurality of the votes cast at the annual meeting of the members of the Association immediately following the designation and selection of the members of the Board of Directors whom Developer shall be entitled to designate and select.

A TRUE COPY
CERTIFICATION ON LAST PAGE
J.K. BARTON, CLERK

(iii) Vacancies in the Board of Directors may be filled until the date of the next annual meeting by the remaining Directors, except that should any vacancy in the Board of Directors be created in any directorship previously filled by any person designated and selected by Developer, such vacancy shall be filled by Developer's designating and selecting, by written instrument delivered to any officer of the Association, the successor Director to fill the vacated directorship for the unexpired term thereof.

(iv) In the election of Directors, there shall be appurtenant to each Unit as many votes for Directors as there are Directors to be elected; provided, however, that no member or owner of any Unit may cast more than one vote for any person nominated as a Director, it being the intent hereof that voting for Directors shall be non-cumulative.

(v) In the event that Developer, in accordance with the privilege granted unto it, selects any person or persons to serve on any Board of Directors of the Association, the said Developer shall have the absolute right at any time, in its sole discretion, to replace any such person or persons with another person or persons to serve on said Board of Directors. Replacement of any person or persons selected by Developer to serve on the Board of Directors of the Association shall be made by written instrument delivered to any officer of the Association, which instrument shall specify the name or names of the person or persons designated as successor or successors to the persons so removed from said Board of Directors. The removal of any Director and designation of his successor shall be effective immediately upon delivery of such written instrument by Developer to any officer of the Association.

c. The organizational meeting of a newly elected Board of Directors shall be held within ten (10) days of their election, at such time and at such place as shall be fixed by the Directors at the meeting at which they were elected, and no further notice of the organizational meeting shall be necessary provided a quorum shall be present.

d. Regular meetings of the Board of Directors may be held at such time and place as shall be determined from time to time by a majority of the Directors. Notice of regular meetings shall be given to each Director, personally or by mail, telephone or telegram, at least three (3) days prior to the day named for such meeting, unless notice is waived.

e. Special meetings of the Directors may be called by the President, and must be called by the Secretary at the written request of one-third (1/3) of the votes of the Board. Not less than ten (10) days' notice of a meeting shall be given to each Director, personally or by mail, telephone or telegram, which notice shall state the time, place and purpose of the meeting.

A TRUE COPY
CERTIFICATION ON LAST PAGE
J.K. BASTON, CLERK

f. Any Director may waive notice of a meeting before or after the meeting, and such waiver shall be deemed equivalent to the giving of notice.

g. A quorum at a Directors' meeting shall consist of the Directors entitled to cast a majority of the votes of the entire Board. The acts of the Board approved by a majority of the votes present at the meeting at which a quorum is present, shall constitute the acts of the Board of Directors, except as specifically otherwise provided in the Articles of Incorporation, these By-Laws or the Declaration of Condominium. If any Directors' meeting cannot be organized because a quorum has not attended, or because the greater percentage of the Directors required to constitute a quorum for particular purposes has not attended, wherever the latter percentage of attendance may be required as set forth in the Articles of Incorporation, these By-Laws or the Declaration of Condominium, the Directors who are present may adjourn the meeting from time to time until a quorum, or the required percentage of attendance if greater than a quorum, is present. At any adjourned meeting, any business which might have been transacted at the meeting as originally called may be transacted without further notice.

h. The presiding officer of Directors' meetings shall be Chairman of the Board, if such an officer has been elected; and if none, then the President shall preside. In the absence of the presiding officer, the Directors present shall designate one of their number to preside.

i. Directors' fees, if any, shall be determined by the members.

j. All of the powers and duties of the Association shall be exercised by the Board of Directors, including those existing under the common law and statutes, the Articles of Incorporation of the Association, these By-Laws and the Declaration of Condominium. Such powers and duties shall be exercised in accordance with said Articles of Incorporation, these By-Laws and the Declaration of Condominium, and shall include, without limiting the generality of the foregoing, the following:

(i) To make, levy and collect assessments against members and members' Units to defray the cost of operation of the Condominium established by Developer on lands as described in Article II of the Articles of Incorporation, and to use the proceeds of said assessments in the exercise of the powers and duties granted unto the Association.

(ii) The maintenance, repair, replacement, operation and management of the Condominium wherever the same is required to be done and accomplished by the Association for the benefit of its members;

(iii) The reconstruction of Improvements after casualty, and the further Improvement of the property, real and personal;

(iv) To make and amend regulations governing the use of the property, real and personal, in, on or about the Condominium, so long as such regulations or amendments thereto do not conflict with the restrictions and limitations which may be placed upon the use of such property under the terms of the Articles of Incorporation and Declaration of Condominium;

(v) To approve or disapprove proposed purchasers and lessees of Units in the manner specified in the Declaration of Condominium;

(vi) To acquire, operate, lease, manage and otherwise trade and deal with property, real and personal, including Units in the Condominium, as may be necessary or convenient in the operation and management of the Condominium, and in accomplishing the purposes set forth in the Declaration of Condominium;

(vii) To contract for the management of the Condominium, and to designate to such contractor all of the powers and duties of the Association, except those which may be required by the Declaration of Condominium to have approval of the Board of Directors or membership of the Association;

(viii) To enforce by legal means the provisions of the Articles of Incorporation and By-Laws of the Association, the Declaration of Condominium and the regulations hereinafter promulgated governing use of the property in the Condominium;

(ix) To pay all taxes and assessments which are liens against any part of the Condominium other than Units and the appurtenances thereto, and to assess the same against the members and their respective Units subject to such liens;

(x) To carry insurance for the protection of the members and the Association against casualty and liability;

(xi) To pay all costs of power, water, sewer and other utility services rendered to the Condominium and not billed to the owners of the separate Units within the Condominium; and

(xii) To employ personnel for reasonable compensation to perform the services required for proper administration of the purposes of the Association.

k. The first Board of Directors of the Association shall be comprised of the three (3) persons designated to act and serve as Directors in the Articles of Incorporation, which said persons shall serve until their successors are elected at the first annual meeting of the members of the Association; provided, however, that any election of Directors shall be subject to all of the rights hereinabove reserved to Developer by Section 4(a) of these By-Laws.

ATRUE COPY
CERTIFICATION ON LAST PAGE
J.K. BARTON, CLERK

l. The undertakings and contracts authorized by said first Board of Directors shall be binding upon the Association in the same manner as though such undertakings and contracts had been authorized by the first Board of Directors duly elected by the membership, so long as any undertakings and contracts are within the scope of the powers and duties which may be exercised by the Board of Directors of the Association in accordance with all applicable Condominium documents.

m. Any one or more of the members of the Board of Directors of the Association may be removed, either with or without cause, at any time by a vote of the members owning a majority of the Units in the Condominium, at any special meeting called for such purpose, or at the annual meeting; provided, however, that only Developer shall have the right to remove a Director appointed by it.

5. OFFICERS

a. The executive officers of the Association shall be a President, who shall be a Director, a Vice-President, a Secretary-Treasurer and such other assistants or vice officers as the Board of Directors may determine, all of whom shall be elected annually by the Board of Directors and who may be peremptorily removed by vote of the Directors at any meeting. The Board of Directors from time to time shall elect such other officers and designate their powers and duties as the Board shall find to be required to manage the affairs of the Association.

b. The President shall be the chief executive officer of the Association. He shall have all of the powers and duties which are usually vested in the office of President of an association, including but not limited to the power to appoint committees from among the members from time to time, as he may in his discretion determine appropriate, to assist in the conduct of the affairs of the Association.

c. The Vice-President shall perform the duties of President in the event of the President's death, inability or refusal to act. In such event, the Vice-President shall have all the powers of and be subject to all the restrictions upon the President.

d. The Secretary shall keep the minutes of all proceedings of the Directors and the members. He shall attend to the giving and serving of all notices to the members and Directors, and such other notices required by law. He shall have the custody of the seal of the Association and affix the same to instruments requiring a seal when duly signed. He shall keep the records of the Association, except those of the Treasurer, and shall perform all other duties incident to the office of secretary of an association and as may be required by the Directors or President.

ATRUE COPY
CERTIFICATION ON LAST PAGE
J.K. BARTON, CLERK

e. The Treasurer shall have custody of all of the property of the Association, including funds, securities and evidences of indebtedness. He shall keep the assessment rolls and accounts of the members; he shall keep the books of the Association in accordance with good accounting practices; and he shall perform all other duties incident to the office of Treasurer.

f. The compensation of all officers and employees of the Association shall be fixed by the Directors. This provision shall not preclude the Board of Directors from employing a Director as an employee of the Association nor preclude the contracting with a Director for the management of the Condominium.

6. FISCAL MANAGEMENT

a. Accounts. The receipts and expenditures of the Association will be credited and charged to such accounts as shall be appropriate. All expenditures will be common expenses.

b. Budget. The Board of Directors will adopt a budget for each fiscal year that will include the estimated funds required to defray current expenditures and to provide and maintain funds for any other accounts and reserves, according to good accounting practices.

Copies of the budget and proposed assessments will be transmitted to each member on or before December 1 preceding the year for which the budget is made. If the budget is amended subsequently, a copy of the amended budget will be furnished to each member.

c. Assessments. Assessments against Unit owners for their shares of the items of the budget will be made for the calendar year annually in advance on or before December 20 preceding the year for which the assessments are made. Such assessments will be due in equal monthly installments on the first day of each month of the year for which the assessments are made. The Board of Directors shall, in its sole discretion, have the right to collect assessments in equal quarterly installments on the first day of January, April, July and October of the year. If an annual assessment is not made as required, an assessment will be presumed to have been made in the amount of the last prior assessment and monthly installments on such assessment will be due upon each installment payment date until changed by an amended assessment. In the event the annual assessment proves to be insufficient, the budget and assessments may be amended at any time by the Board of Directors; and the unpaid assessment for the remaining portion of the calendar year for which the amended assessment is made will be due in equal monthly installments on the first day of each month remaining in the year for which such amended assessment is made.

d. Acceleration of assessment installments upon default. If a Unit owner shall be in default in the payment of an installment upon an assessment, the Board of Directors may accelerate the remaining installments of the assessment upon notice to the Unit owner, and then the unpaid balance of the assessment will come due upon the date stated in the notice, but not less than ten (10) days after delivery of the notice to the Unit owner, or not less than twenty (20) days after the mailing of such notice to him by registered or certified mail, whichever shall first occur.

e. Assessments for emergencies. Assessments for common expenses for emergencies that cannot be paid from the annual assessments for common expenses will be made only after notice of the need for such is given to the members. After such notice and upon approval by more than one-half (1/2) of the members, the assessment will become effective, and it will be due after thirty (30) days' notice in such manner as the Board of Directors of the Association may require in the notice of assessment.

f. The depository of the Association will be such bank or banks as shall be designated from time to time by the Directors and in which the moneys of the Association will be deposited. Withdrawals of moneys from such accounts will be only by checks signed by such persons as are authorized by the Directors.

g. An audit of the accounts of the Association shall be made annually by a Certified Public Accountant, and a copy of the report shall be furnished to each member not later than April 1 of the year following the year for which the report is made.

7. PARLIAMENTARY RULES

Roberts' Rules of Order (latest edition) shall govern the conduct of corporate proceedings when not in conflict with the Articles of Incorporation and these By-Laws or with the Statutes of the State of Florida.

8. AMENDMENTS TO BY-LAWS

Amendments to these By-Laws shall be proposed and adopted in the following manner:

a. Amendments to these By-Laws may be proposed by the Board of Directors of the Association acting upon vote of the majority of the Directors, or by a majority of members of the Association, whether meeting as members or by instrument in writing signed by them.

ATRUE COPY
CERTIFICATION ON LAST PAGE
J.K. BARTON, CLERK

b. Upon any amendment or amendments to these By-Laws being proposed by said Board of Directors or members, such proposed amendment or amendments shall be transmitted to the President of the Association, or other officer of the Association in absence of the President, who shall thereupon call a special joint meeting of the members of the Board of Directors of Association and the membership for a date not sooner than twenty (20) days nor later than sixty (60) days from receipt by such officer of the proposed amendment or amendments, and it shall be the duty of the Secretary to give to each member written or printed notice of such meeting in the same form and in the same manner as notice of the call of a special meeting of the members is required as herein set forth.

c. In order for such amendment or amendments to become effective, the same must be approved by an affirmative vote of seventy-five percent (75%) of the entire membership of the Board of Directors and by an affirmative vote of seventy-five percent (75%) of the members. Thereupon, such amendment or amendments to these By-Laws shall be transcribed, certified by the President and Secretary of the Association, and a copy thereof shall be recorded in the public records of Indian River County, Florida, within ten (10) days from the date on which any amendment or amendments have been affirmatively approved by the Directors and members.

d. At any meeting held to consider such amendment or amendments to the By-Laws, the written vote of any member of the Association shall be recognized if such member is not in attendance at such meeting or represented thereat by proxy, provided such written vote is delivered to the Secretary of the Association at or prior to such meeting.

e. Notwithstanding the foregoing provisions of this Article 8, no amendment to these By-Laws which shall abridge, amend or alter the right of Developer to designate and select members of each Board of Directors of the Association, as provided in Article 4 hereof, may be adopted or become effective without prior written consent of Developer; and further provided that these By-Laws may be amended by action of a majority of the Board of Directors of the Association without vote of the membership, so long as Developer shall have the right to designate and select members of each Board of Directors of the Association, as provided in Article 4 hereof, or until such time as Developer may have relinquished its right to designate and select members of each Board of Directors or may waive the provisions of this paragraph of these By-Laws, by instrument in writing executed with the formalities of a deed.

The foregoing were adopted as the By-Laws of SPINDRIFT CONDOMINIUM ASSOCIATION OF VERO BEACH, INC., a corporation not for profit under the

laws of the State of Florida, at the first meeting of the Board of Directors on
the 17th day of March, 1981.

APPROVED:

President

Secretary

STATE OF FLORIDA
INDIAN RIVER COUNTY
THIS IS TO CERTIFY THAT THIS IS A
TRUE AND CORRECT COPY OF THE
ORIGINAL ON FILE IN THIS OFFICE.



J.K. BARTON, CLERK
BY 
DEPUTY CLERK
DATE 3/2/1999

A-2

JOB NO.	1720
DATE	1/20/50
NO. OF SHEETS	10
SHEET NO.	2

PROPERTY CONDITIONS
 THE SHOWN CONDITIONS OF THIS BLOCK
 WERE MADE BY THE ARCHITECT ON THE DATE SHOWN

DATE	1/20/50
NO. OF SHEETS	10
SHEET NO.	2

DONALD FREDRICK EVANS ASSOCIATES
 ARCHITECTURE & PLANNING
 107 PARK LACE STREET
 DELAWARE, DELAWARE 19801
 PHONE: 302-843-2370

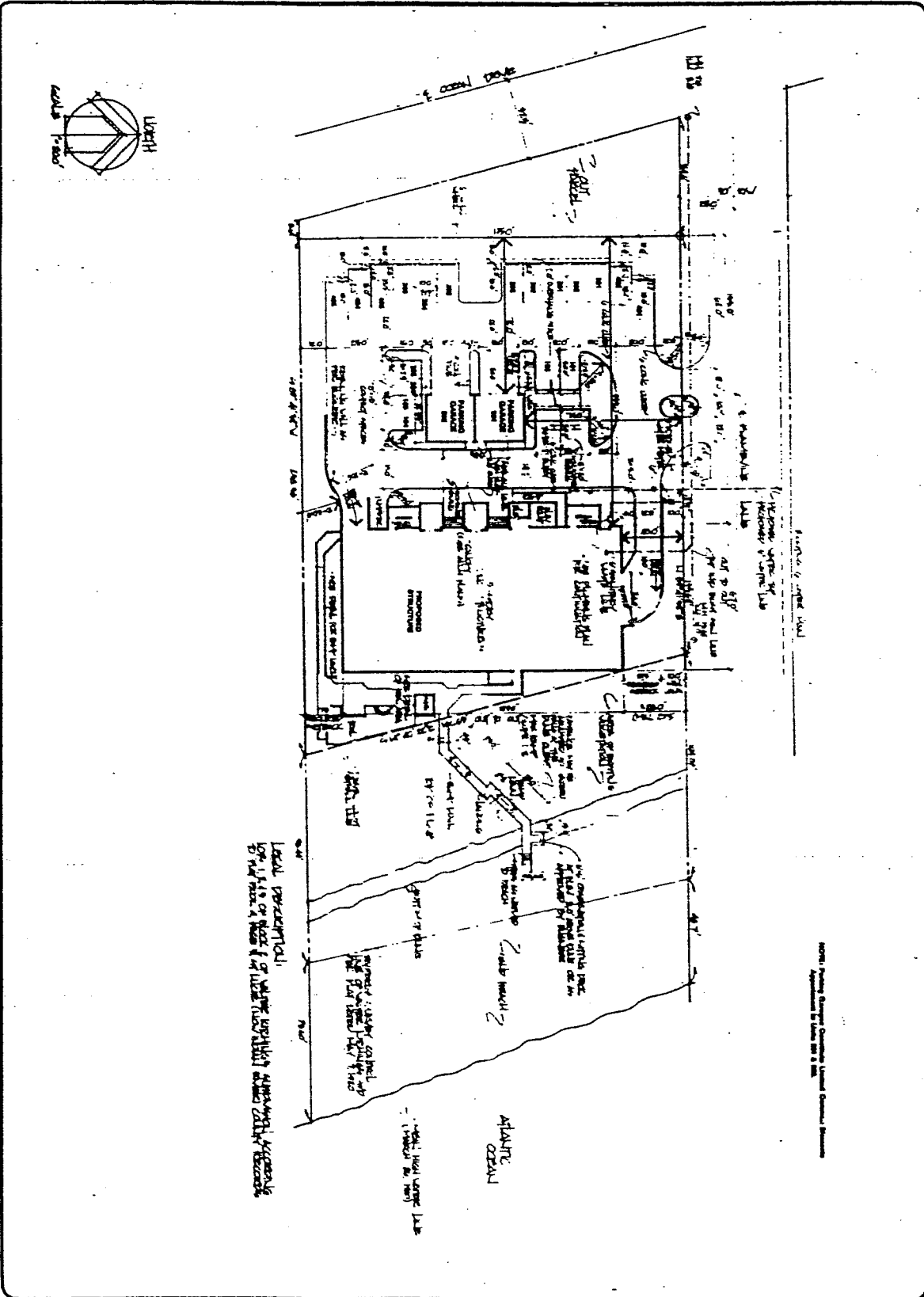

A TRUE COPY
 CERTIFICATION ON LAST PAGE
 J.K. BARTON, CLERK

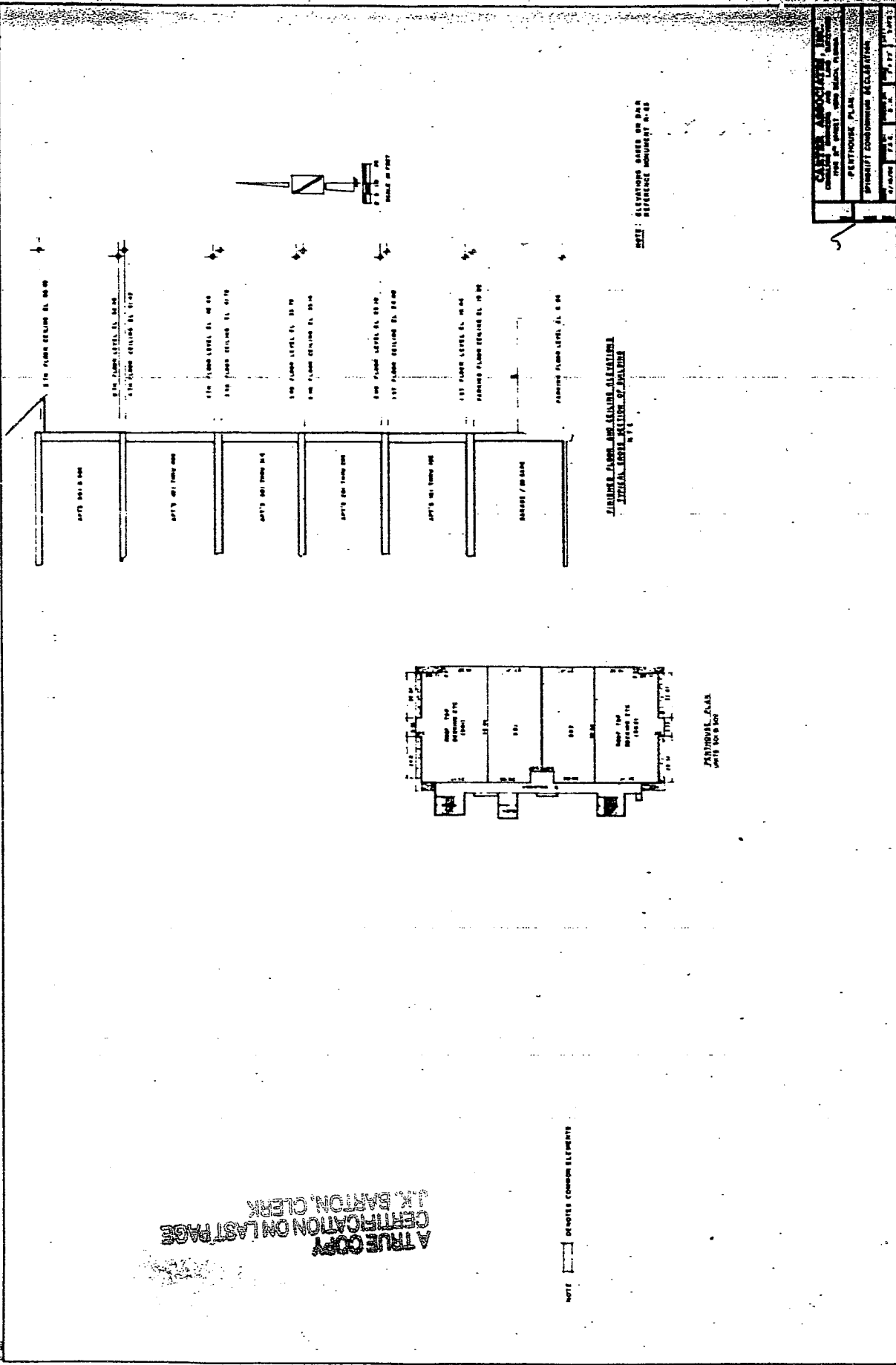

CARTER ASSOCIATES, INC.	
CONSULTING ARCHITECTS AND ENGINEERS	
1000 20 th STREET, SUITE 2000, WASHINGTON, D.C. 20036	
PENTHOUSE PLAN	
PUNJABI CONDOMINIUM RECALCULATION	
DATE	NO. 1
7/2/80	7/17/80

NOTE: ELEVATIONS SHOWN ON PLAN
REFERENCE HORIZONTAL 8-10

STRUCTURAL PLAN AND FOUNDATION DRAWINGS
SHEETS 1-11

MEZANINE AREA
SHEET NO. 8 OF 8

NOTE: SEE NOTES COMMON ELEMENTS

A TRUE COPY
CERTIFICATION ON LAST PAGE
J.K. BARTON, CLERK

A TRUE COPY
 CERTIFICATION ON LAST PAGE
 J.K. BARTON, CLERK

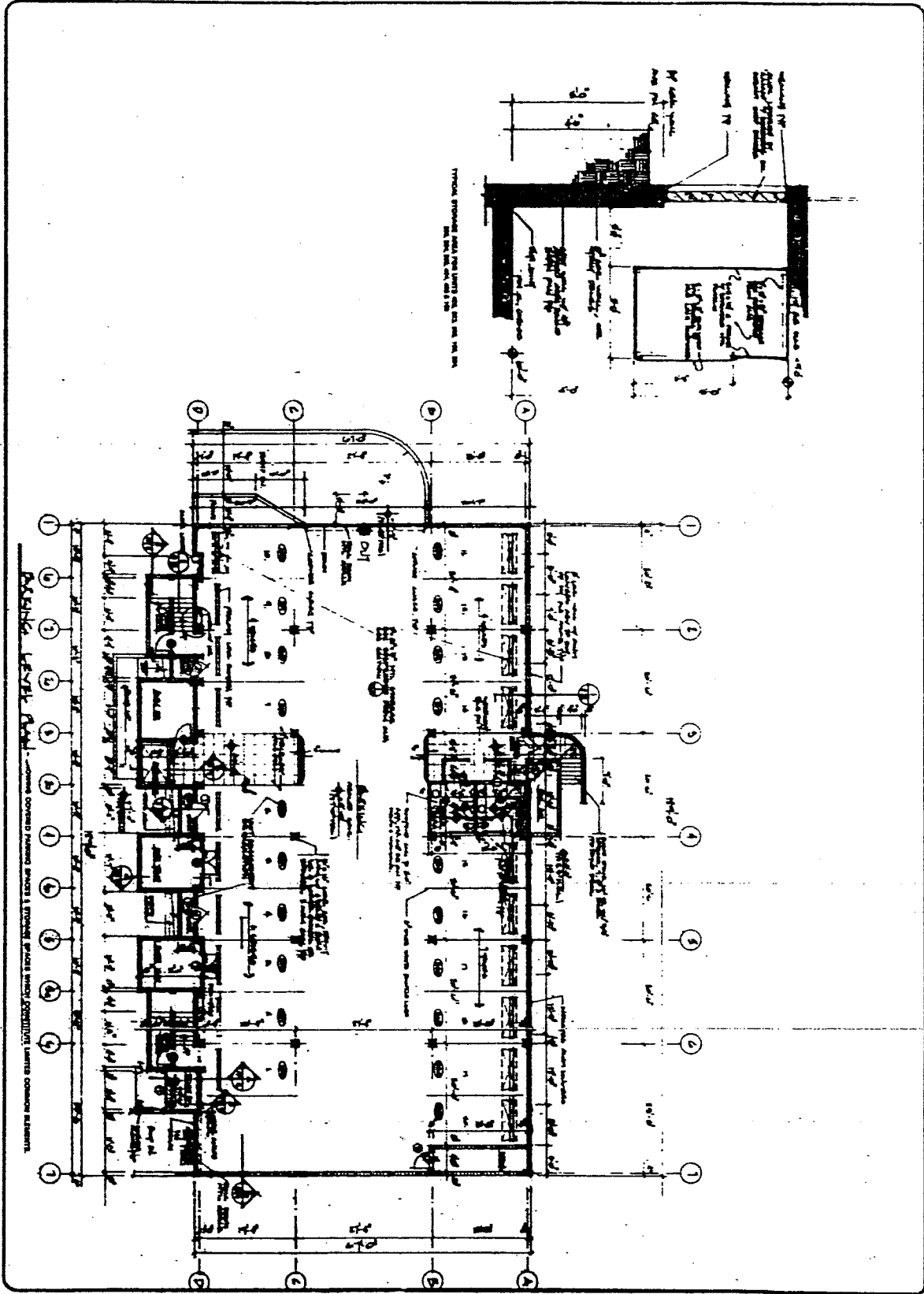

A-3	JOB NO. 19200	REVISIONS	 <p>DONALD FREDRICK EVANS ASSOCIATES ARCHITECTURE & PLANNING</p>	
	DATE 2. 2. 64			1971 BANK LAKE STREET ORLANDO, FLORIDA 32803
	OWNER BY			PHONE: 305-848-8270

O.R. BR. 641 Pg. 2181

A TRUE COPY
 CERTIFICATION ON LAST PAGE
 J.E. BARTON, CLERK

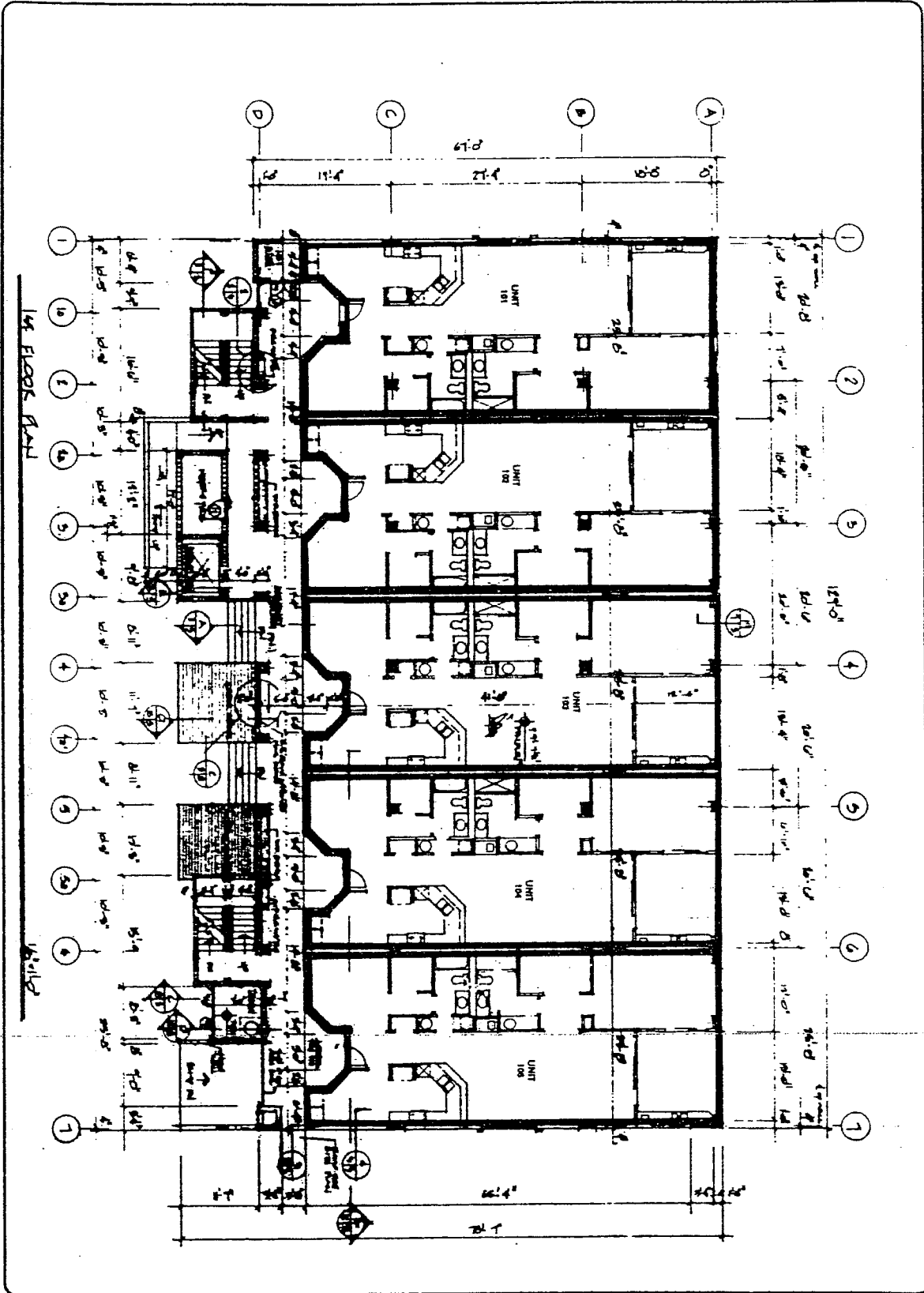

A-4	JOB NO. ACD	REVISIONS
	DATE	
	DRAWN BY	
	SPINDRIFT CONDOMINIUM FOR THE SPINDRIFT CORPORATION OF VERO BEACH VERO BEACH, FLORIDA	



**DONALD
 FREDRICK
 EVANS
 ASSOCIATES**
 ARCHITECTURE & PLANNING

131 PARK LAKE STREET
 ORLANDO, FLORIDA 32803
 PHONE: 306-948-8310

O.R. BK. 641 PG. 2182

A TRUE COPY
 CERTIFICATION ON LAST PAGE
 J.K. BARTON, CLERK

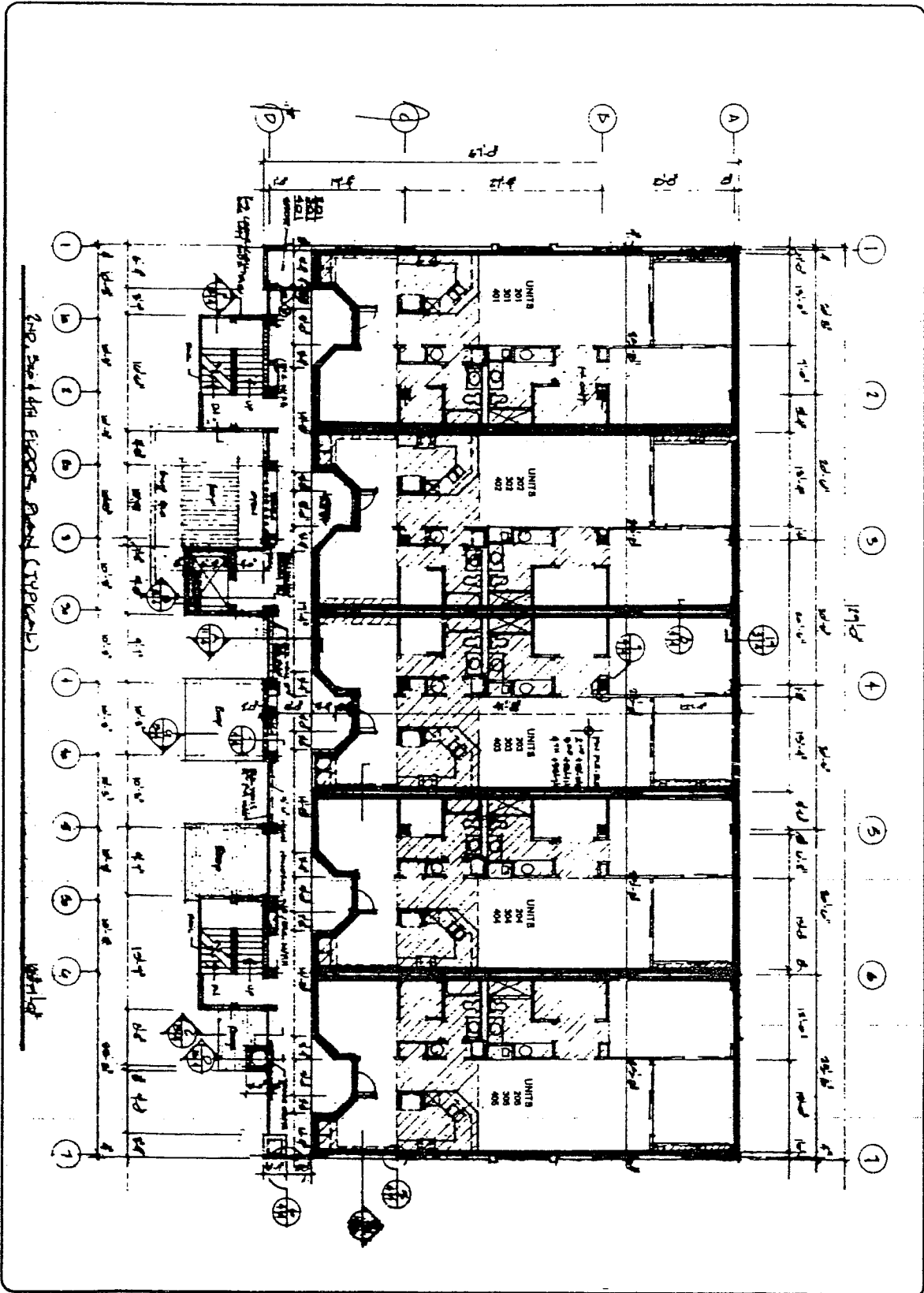

2nd, 3rd & 4th Floors, Bldg. (Typical)

A-5	JOB NO. 4-22	REVISIONS	 DONALD FREDRICK EVANS ASSOCIATES ARCHITECTURE & PLANNING	121 PARK LAKE STREET ORLANDO, FLORIDA 32802 PHONE: 308-848-8270
	DATE:			
	SPINDRIFT CONDOMINIUM			
	FOR THE SPINDRIFT CORPORATION OF VERO BEACH VERO BEACH, FLORIDA			

O.R. Bk. 641 Pg. 2183

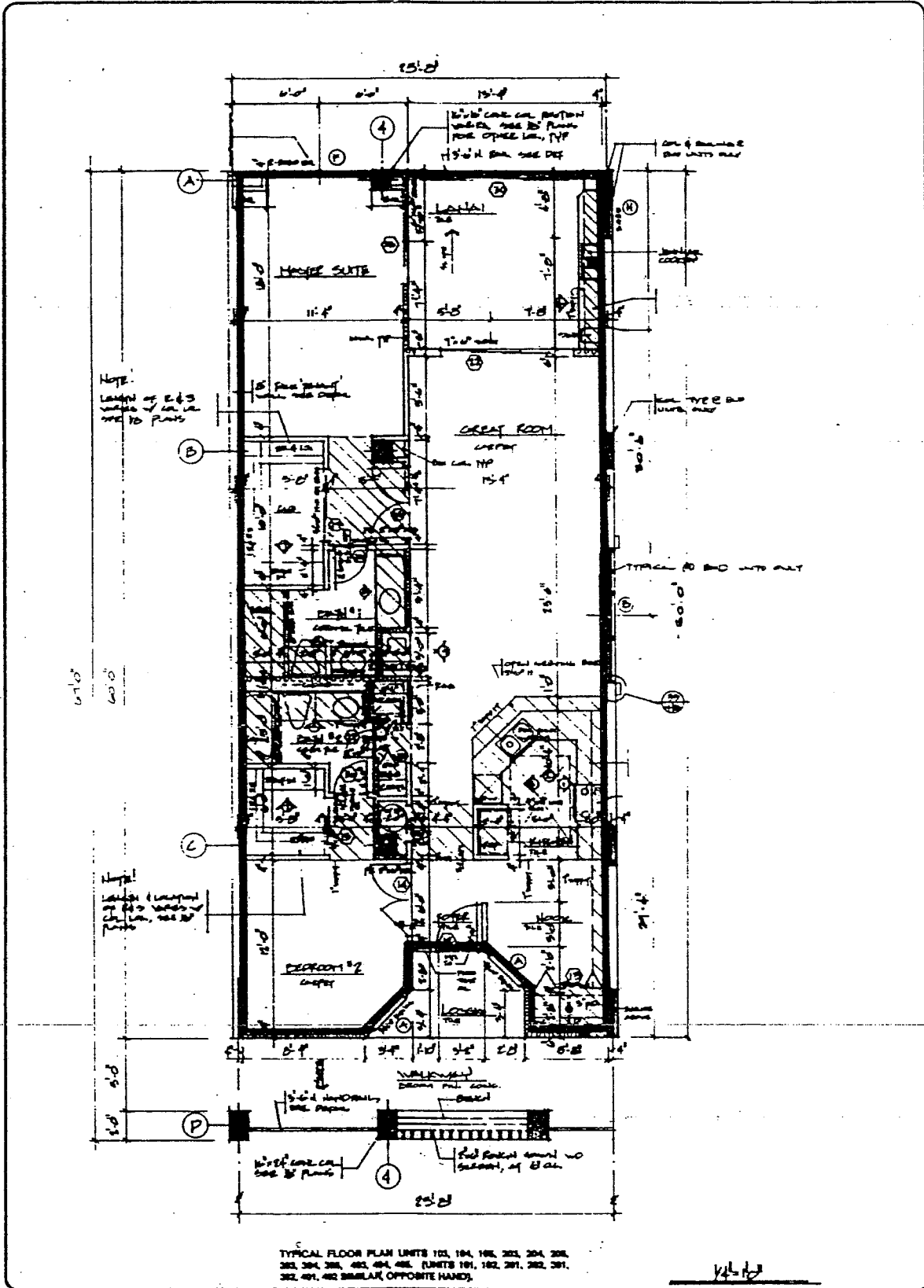

A-7	JOB NO. 19200	REVISED		DONALD FREDRICK EVANS ASSOCIATES ARCHITECTURE & PLANNING	131 BARK LAKE STREET ORLANDO, FLORIDA 32803 PHONE 1 308-548-8370
	DATE: 2. . . .	SPRIBET CONDOMINIUM			
	OWNER: BY:	FOR THE SPURRY CORPORATION OF VERO BEACH VERO BEACH, FLORIDA			

O.R.B.R. 641 Pg. 2185

A TRUE COPY
 CERTIFICATION ON LAST PAGE
 J.K. BARTON, CLERK

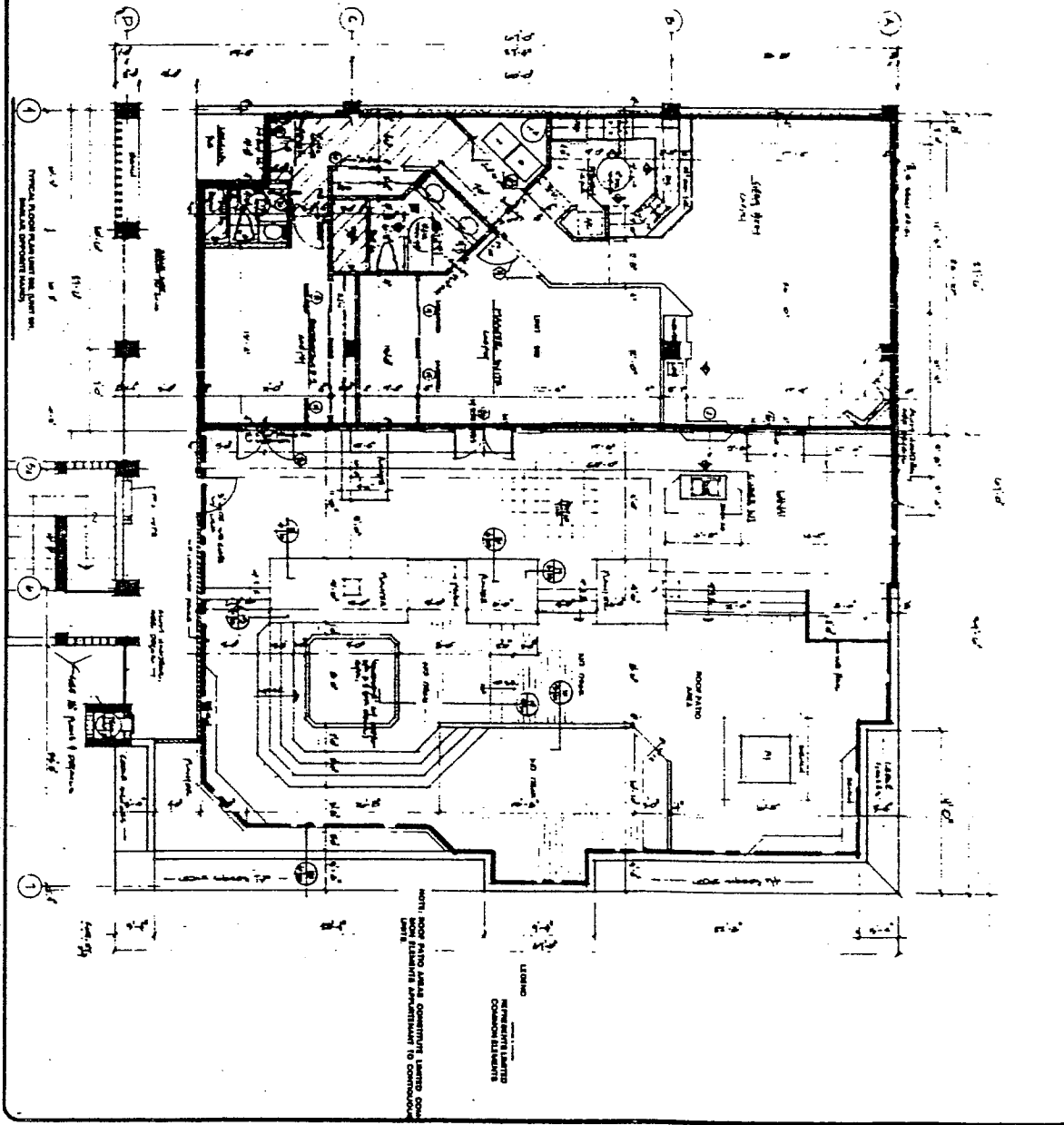

A-8	JOB NO. 4500	REVISED
	DATE 7/1/54	
	PROJECT SPRIBET CONDOMINIUM	
	OWNER THE SPRIBET CORPORATION OF VERO BEACH, FLORIDA	



**DONALD
 FREDRICK
 EVANS
 ASSOCIATES**
 ARCHITECTURE & PLANNING

121 PARK LAKE STREET
 ORLANDO, FLORIDA 32803
 PHONE: 305-842-8210

O.R. BR. 641 Pg. 2186

A TRUE COPY
 CERTIFICATION ON LAST PAGE
 J.K. BARTON, CLERK

Passage with chimney

Admitt

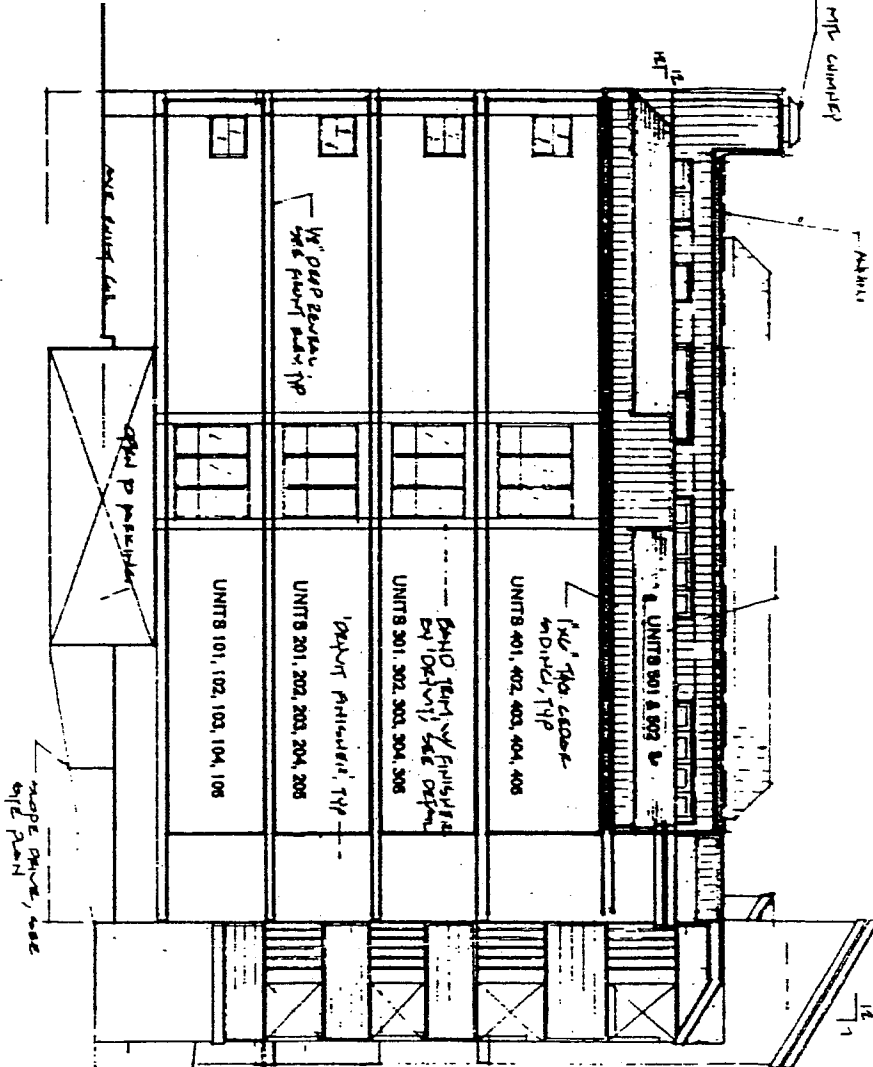

NORTH ELEVATION (SOUTH ELEVATION, SIMILAR, OPPOSITE HAND).

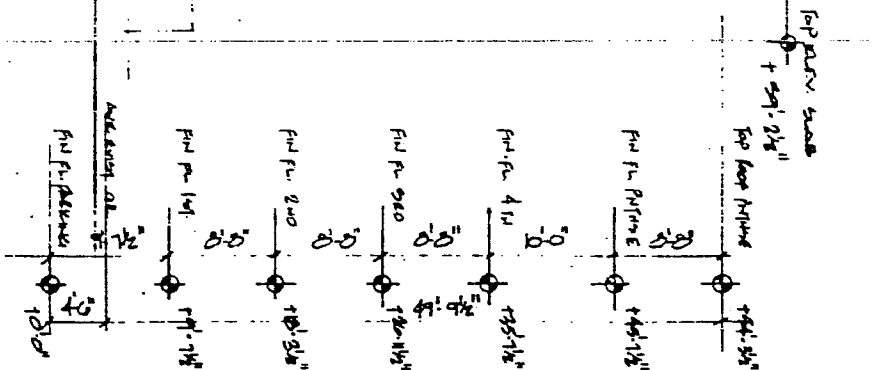

BOOK 064 | PAGE 218.1

A-9	JOB NO. 1420	SPINDRIFT CONDOMINIUM FOR THE SPINDRIFT CORPORATION OF VERO BEACH FLORIDA	REVISED	DONALD FREDRICK EVANS ASSOCIATES ARCHITECTURE & PLANNING	131 PARK LAKE STREET ORLANDO, FLORIDA 32805 PHONE: 305-849-8370
	DATE:				
	DRAWN BY:				
	BY:				

O.R. BR. 641 Pg. 218

A TRUE COPY
CERTIFICATION ON LAST PAGE
J.K. BARTON, CLERK

SPINDRIFT
a Condominium
Indian River County, Florida

I, DANA HOWARD, 1708 - 21st Street, Vero Beach, Florida,
certify as follows:

1. That I am a land surveyor, duly authorized to practice in the State of Florida, having Certificate of Registration No. 2805, State of Florida.

2. That this certificate is made as to SPINDRIFT, a Condominium, located in Indian River County, Florida, and in compliance with Chapter 718, Florida Statutes.

3. That the construction of the improvements described in the foregoing Declaration of Condominium is sufficiently complete so that with the survey of the land as set forth in Exhibit A attached hereto, together with the plot plans as set forth in Exhibit A attached hereto, showing the apartment buildings and common elements, together with the wording of the foregoing Declaration of Condominium, there can be determined therefrom the identification, location and dimensions of each unit, the common elements and limited common elements, and that the aforementioned material is an accurate representation of the location and dimensions of the improvements.

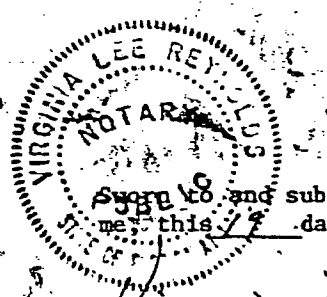

Sworn to and subscribed before me, this 27 day of April, 1982.

Virginia Lee Reynolds
Notary Public, State of Florida at Large.
My commission expires:

NOTARY PUBLIC STATE OF FLORIDA AT LARGE
MY COMMISSION EXPIRES JULY 12, 1984
BONDED THRU GENERAL INS. UNDERWRITERS

Dana Howard
Dana Howard, Land Surveyor
Certificate of Registration No. 2805
State of Florida

Exhibit 064 PAGE 2189

State of Florida



Department of State

A TRUE COPY
CERTIFICATION ON LAST PAGE
J.K. BARTON, CLERK

I certify that the attached is a true and correct copy of the Articles of Incorporation of SPINDRIFT CONDOMINIUM ASSOCIATION OF VERO BEACH, INC., a corporation not for profit organized under the Laws of the State of Florida, filed on June 30, 1981, as shown by the records of this office.

The charter number for this corporation is 758979.

Given under my hand and the
Great Seal of the State of Florida,
at Tallahassee, the Capital, this the
6th day of July, 1981.

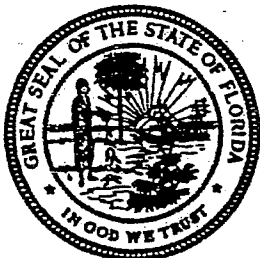

CER 101 Rev. 12-80

George Firestone
Secretary of State